



L-39 Albatros Trainer Jet

64mm EDF with retractable landing gear and navigation lights.

Basic Specifications

Wingspan: 860mm

Length: 1140mm

Empty Weight: 630g

Takeoff Weight: 1300g

Wing Loading: 80g/dm²

Requirements

Motor / EDF: 64mm (4/6S)*1

ESC: 40A*1

Servos: 9g servos*8

Battery: 4S or 6S battery as per configuration

Requirements Transmitter. 6 channels or more

Battery Recommendations

4S Version: 2200-2600mAh 4S battery 6S Version: 2000-3300mAh 6S battery

KIT TYPE

KIT	KIT+ Servos	PNP
Standard 25g worm gear	KIT	KIT
CNC metal shock-absorbing landing gear	9g Servo x 8 (Installed)	9g Servo x 8 (Installed)
4 navigation lights		40A ESC x 1(Installed)
		4S: 2840-3200KV 64mm EDF(Installed)
		6S: 2840-2300KV 64mm EDF(Installed)

Kit Parts List (KIT)

- | | | |
|----------------------------------|------------------------------------|------------------------------|
| 1. Main Wing*1 | 6. Front navigation light cover*2 | 11. Short Y-cable*1 |
| 2. Tail*1 | 7. Hook and loop tape*1 | 12. Quick adjustment lever*1 |
| 3. Fuselage*1 | 8. Pitot tube*2 | 13. EDF fixed screws*2 |
| 4. Front landing gear cover*1 | 9. Pushrods*7 | 14. Fixed screws*6 |
| 5. Side navigation light cover*2 | 10. Front wheel steering pushrod*1 | |

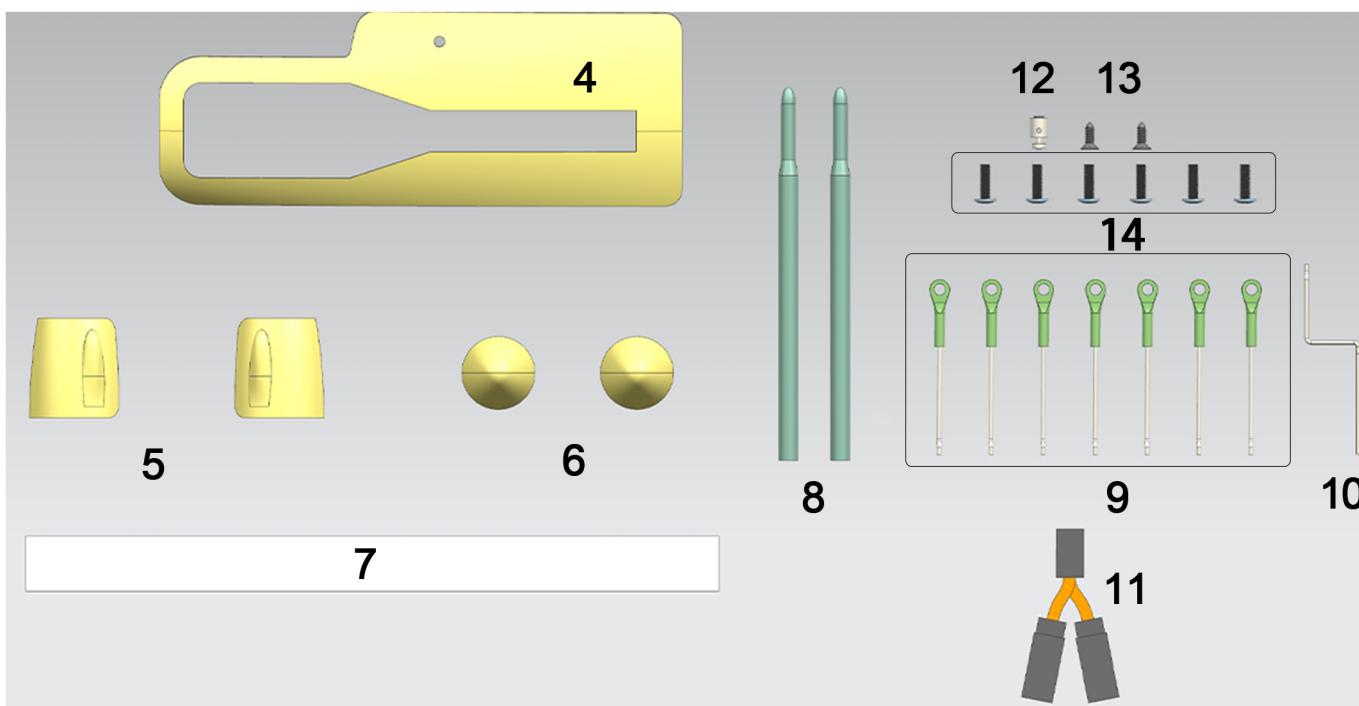
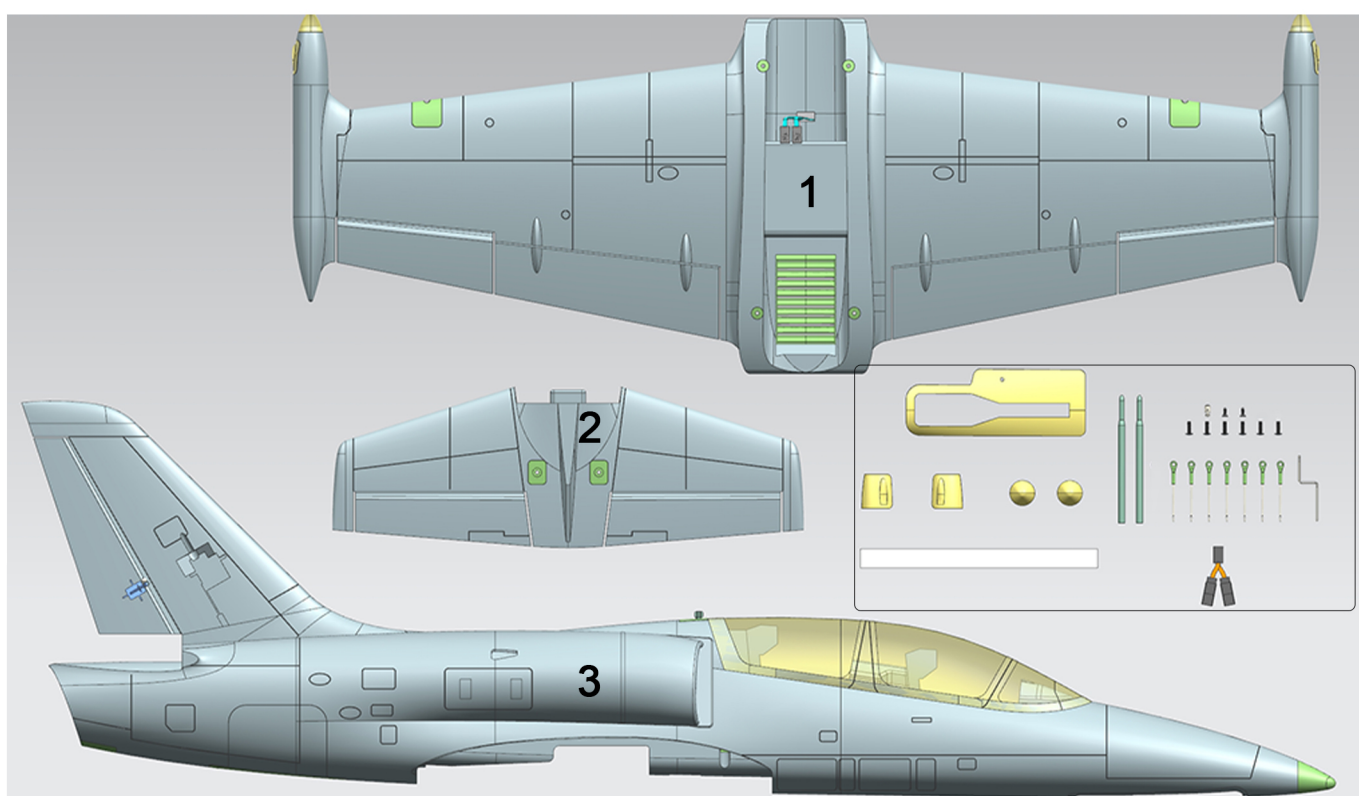

Airframe Installation (Kit Version) Installing

Horizontal Stabilizer Servos

1. Power on the 9g servos and center them before attaching the servo arms. Use foam glue or hot glue to affix the servos securely in their respective slots, ensuring a firm bond. It is recommended to use servos with wire lengths between 10-15cm.

Note: Use one servo with a standard orientation and one with a reverse orientation here.

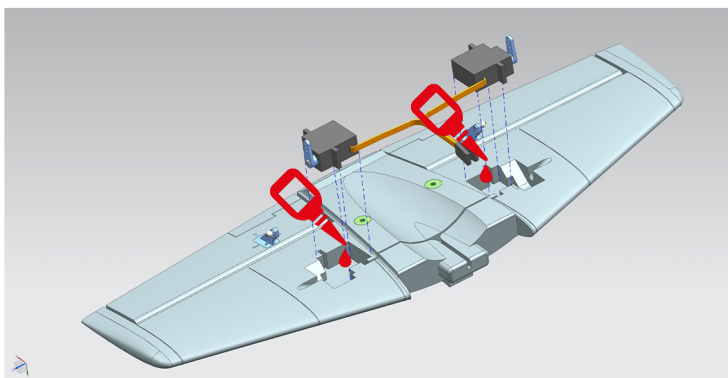

2. Adjust the pushrod length and install it on the servo arm.

Note: For elevator servos, it is recommended to install the pushrods in the second hole from the outside on the servo arm.

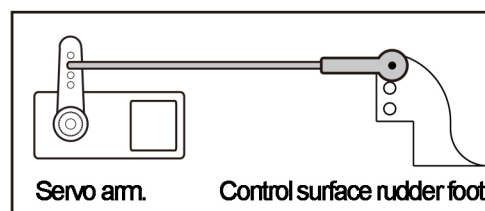
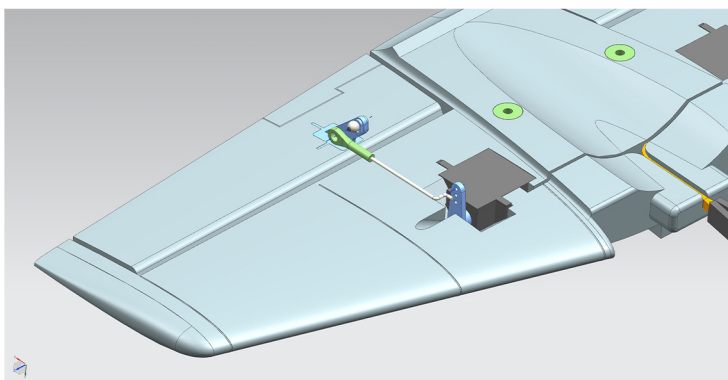

Installing Aileron and Flap Servos

3. Power on the aileron and flap servos separately, center them, and attach the servo arms. Pay attention to the initial position (0-degree) of the flap servo and the direction of the servo arms.

Note: It is recommended to install the pushrods for both aileron and flap servos in the second hole from the outside on the servo arm.

4. After routing the servo wires into the wire channels, secure them with glue.

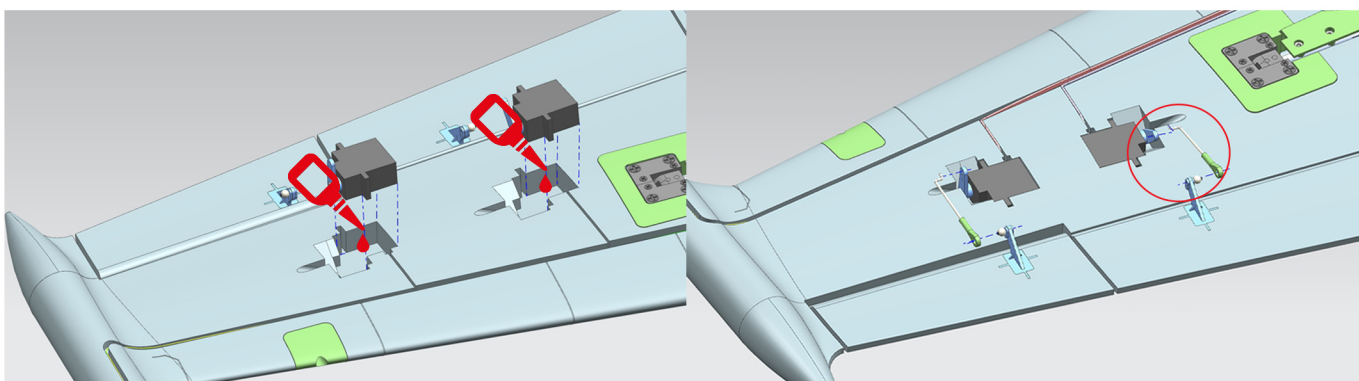
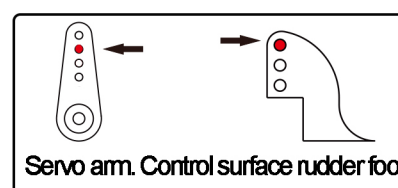

5. Additionally, install the wing servo on the other side in the same manner.

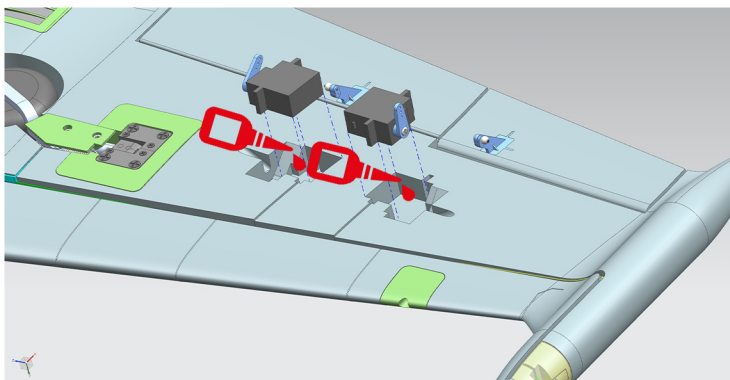

Install the vertical tail servo

6. Power the vertical tail servo to its center position, secure it in the designated location, and thread the servo wires through the corresponding channel into the interior of the aircraft.

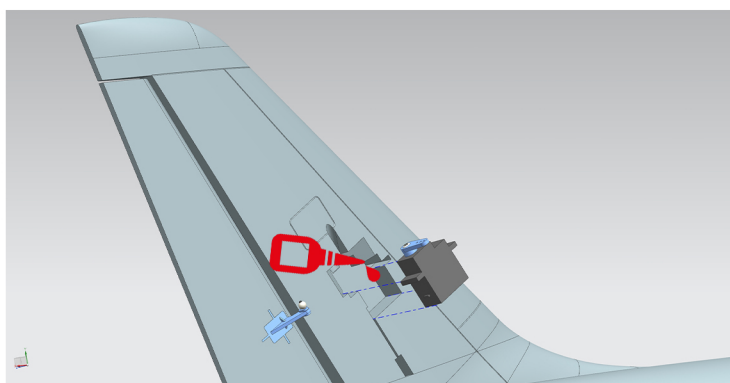

7. Adjust the pushrod length, install the pushrod, and it is recommended to attach it to the second hole on the servo arm.

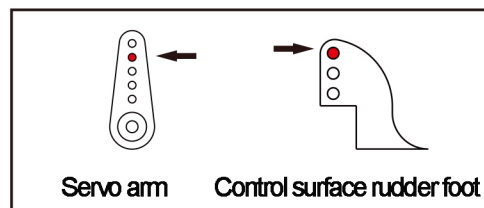
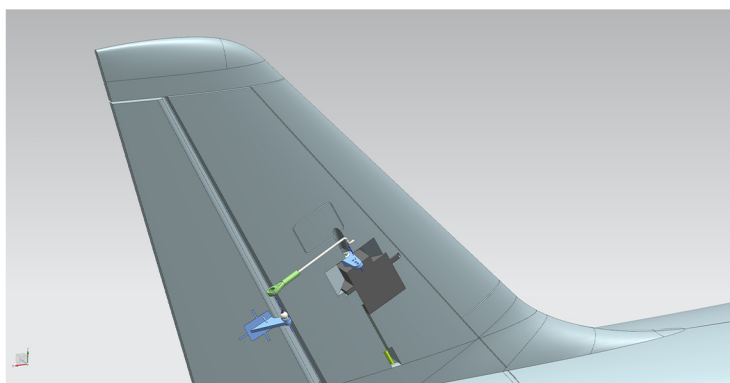

Install the horizontal tail

8. Connect the two horizontal tail servos using a Y-cable and thread them through the pre-drilled hole in the aircraft's body.

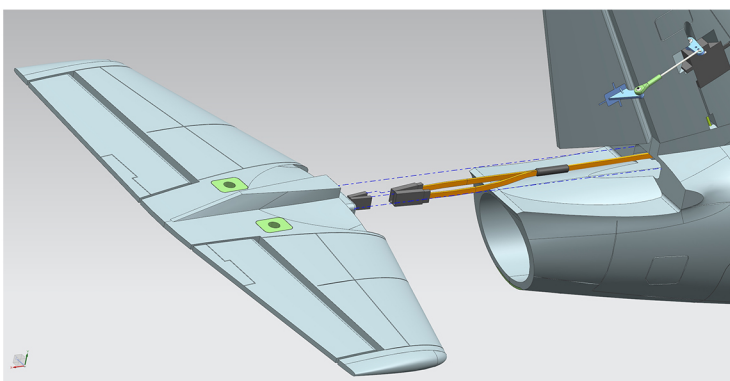

9. Secure the horizontal tail to the aircraft body using the provided hex screws from the accessory kit. (Use a 2.5mm hex wrench, and the screw type should match those used for wing attachment.)

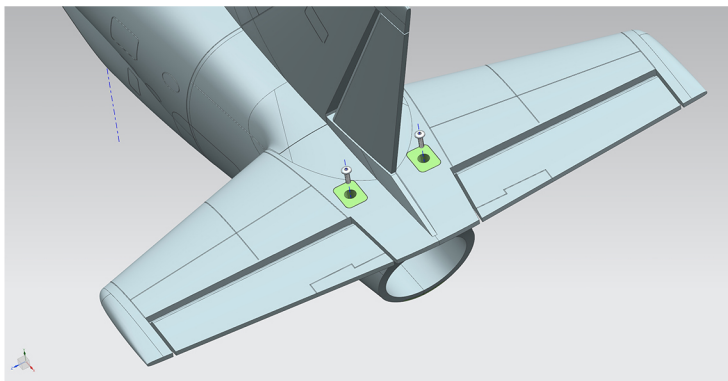

Install the ducting and electronic speed controller (ESC)

10. Connect the ducting and ESC together, power them up to ensure the ducting is rotating in the correct direction, and insert the ESC into the upper portion of the pre-set ESC cooling plate on the back.

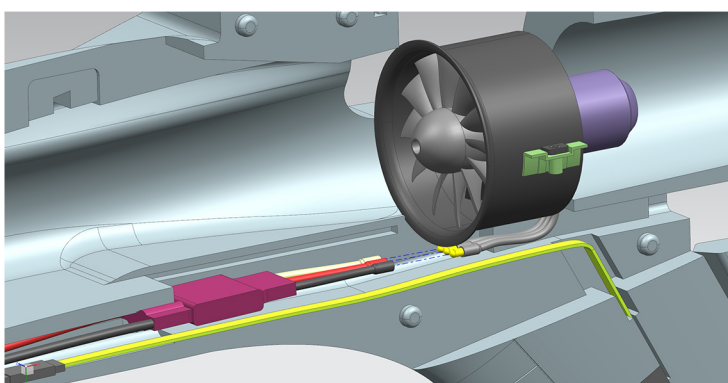

11. Use the two black duct securing screws included in the accessory kit to fasten the duct onto the corresponding plastic mount.

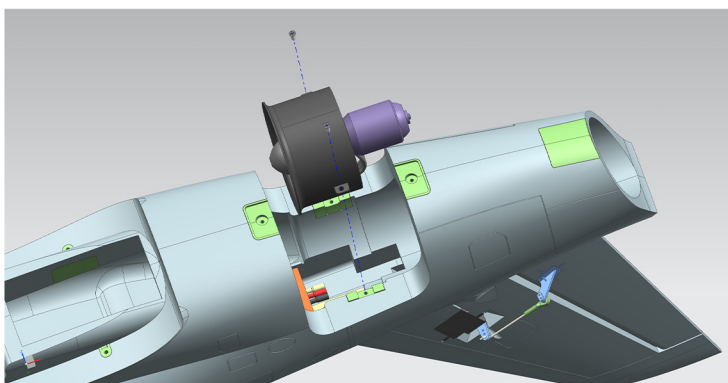

12. Install the duct cover plate and tighten the securing screws.

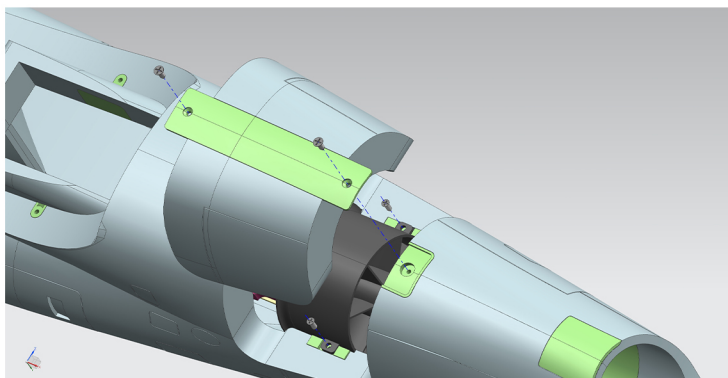

Install the front wheel linkage

13. Power up the landing gear to raise it, center the front wheel steering servo, and install the quick-adjustment mechanism.

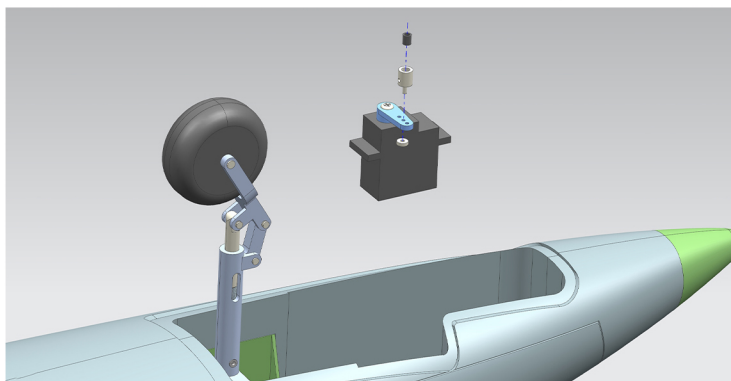

14. Secure the servo in place using adhesive.

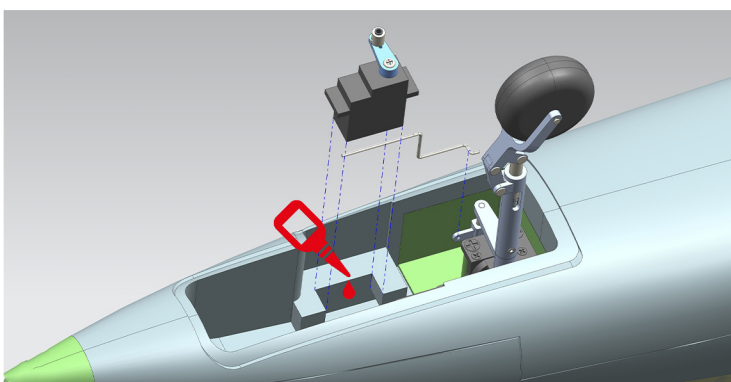

15. Install the linkage between the front wheel steering servo and the front wheel steering arm, then attach the landing gear cover plate.

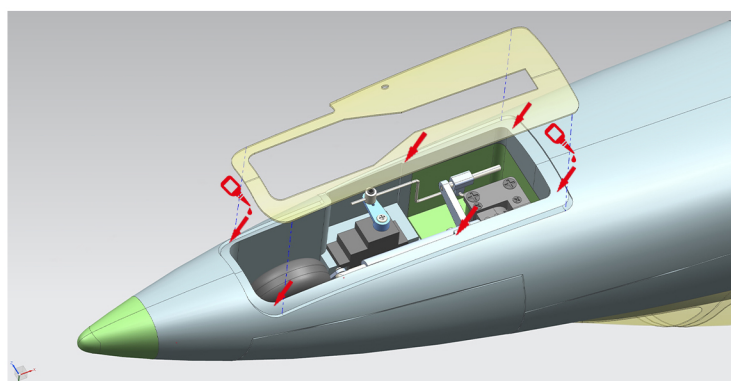
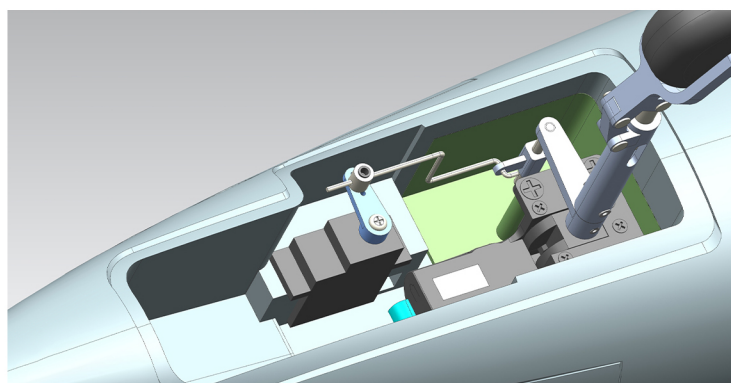

Install the main wing

16. Connect the servo plugs to the designated connectors on the aircraft body following the markings.

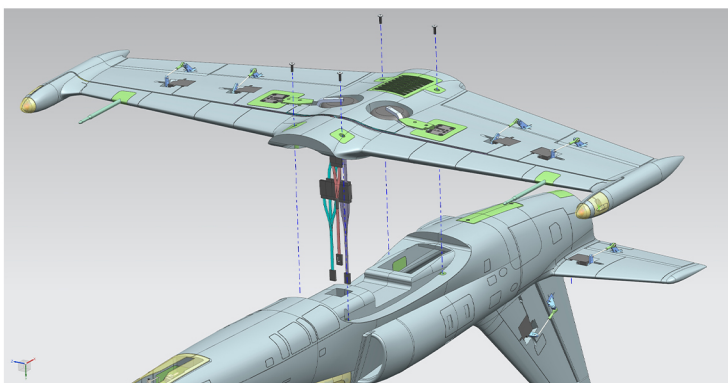

17. Secure the wing to the aircraft body using the screws provided in the accessory kit.

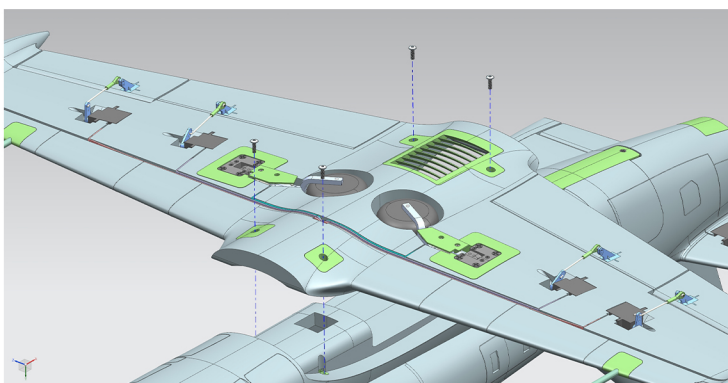

Note: The airspeed tube included with this product is a decorative piece made of rigid material. It is recommended for static display purposes only. To avoid any potential risks during flight, please use this decorative component with caution.

Install the decorative components

18. Insert the airspeed tube into its corresponding base.

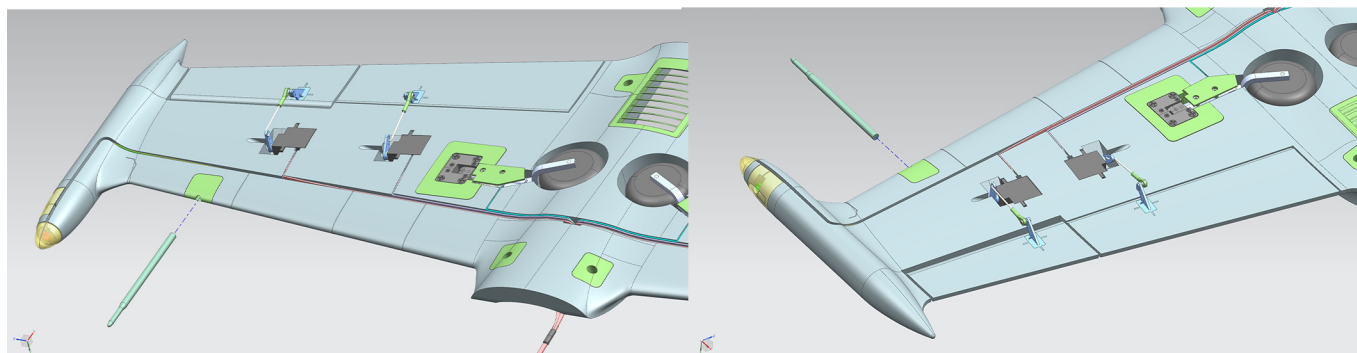

19. Install the navigation lights in the following manner: red on the left, green on the right, and white at the front. Then, glue the light covers in their respective positions.

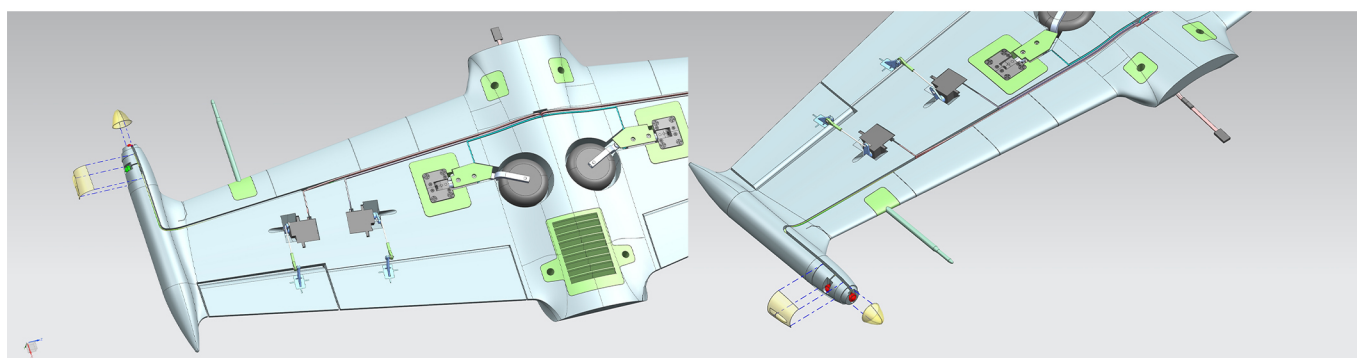

20. With these steps completed, the installation of this product is finished.

Flight Setup

Battery Installation Adjustment

1. Before powering on the aircraft, please first turn on the transmitter's power and ensure the throttle stick is in the low position.
2. Remove the cockpit cover and take off the magic tape on the battery tray.
3. Place the battery inside the battery compartment with the end of the power cord facing towards the rear of the aircraft, and secure the battery with magic tape.
4. Since batteries from different manufacturers may have varying weights, it is necessary to adjust the battery's position to balance the aircraft's center of gravity.

Center of Gravity Adjustment

The center of gravity for this product is located 90mm back from the front edge of the wing. Please adjust the battery position according to the center of gravity point and secure it with battery straps.

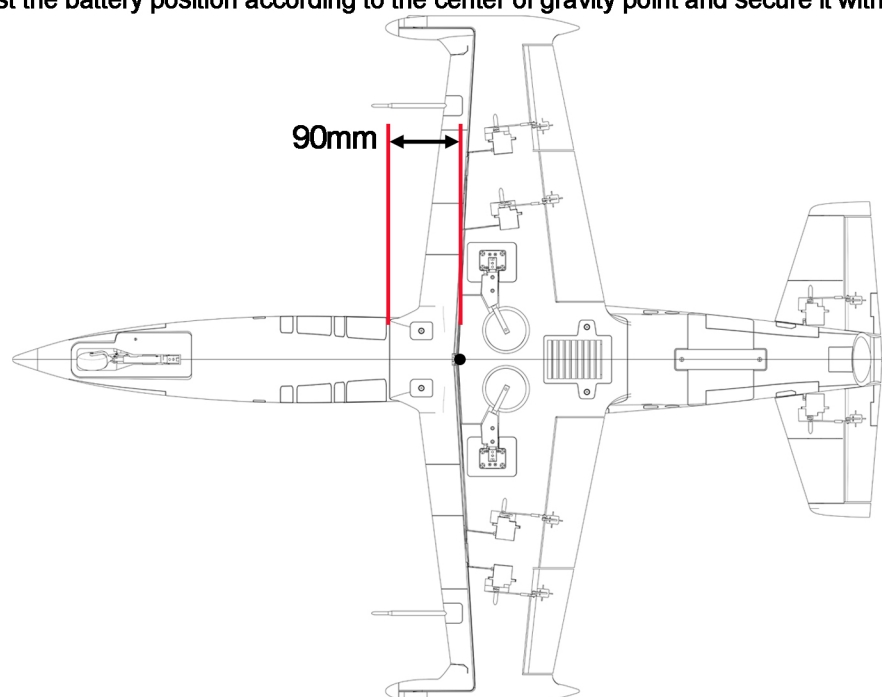

Control Surface Settings

Aileron		Elevator		Turn Rudder	
Right Roll		Climb		Right	
Left Roll		Dive		Turn Left	

Control Surface Adjustment

For safer flight operations, it is recommended to set up dual-rate modes for control surfaces.

- Elevator and aileron control surfaces work well with small deflections and are recommended for continuous use.
- Using large deflections on the rudder during ground operations can reduce the turning radius.
- During aerial flight, using small deflections on the control surfaces can enhance stability.
- If you need to perform high maneuverability maneuvers, you can switch to large deflections.
- The flap servo is a 90-degree servo. When setting the deflection angle, please do not exceed 85 degrees to prevent damaging the servo.

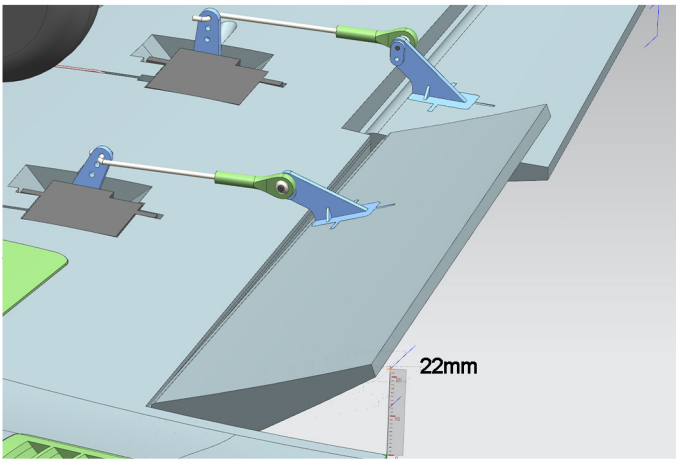

Flaps large control surface (75-85%)

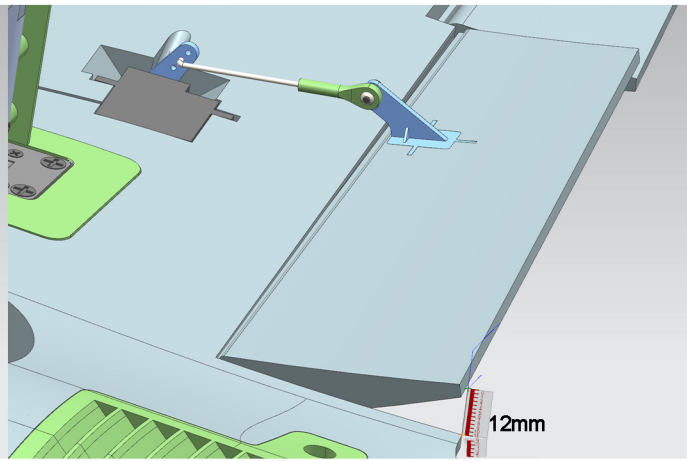

Flaps small control surface (40-50%)

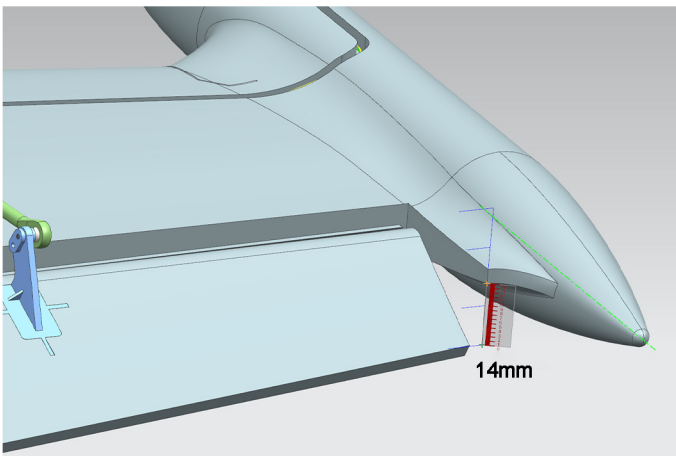

Ailerons large control surface (70-90%)

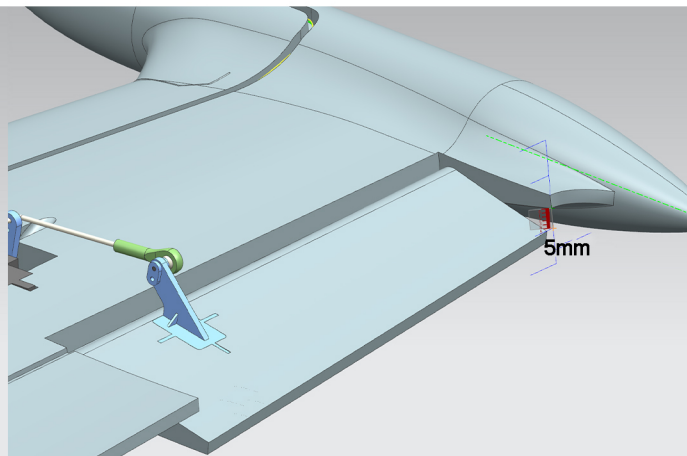

Ailerons small control surface (45-55%)

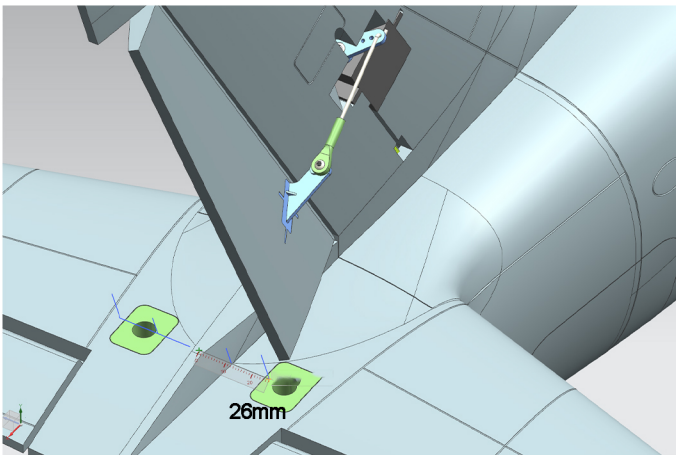

Rudder large control surface (80-90%)

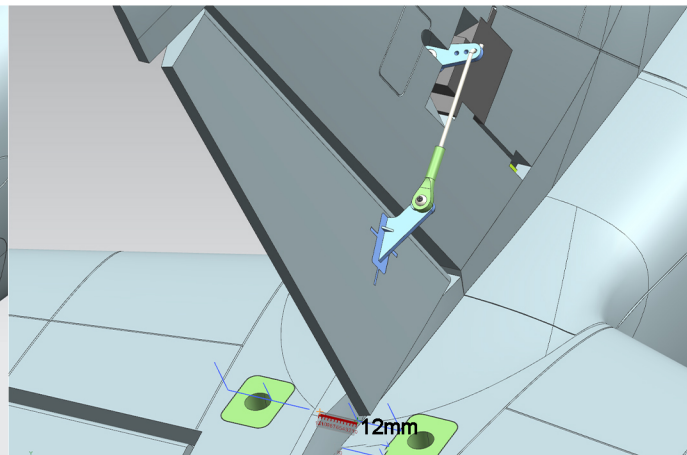

Rudder small control surface (35-45%)

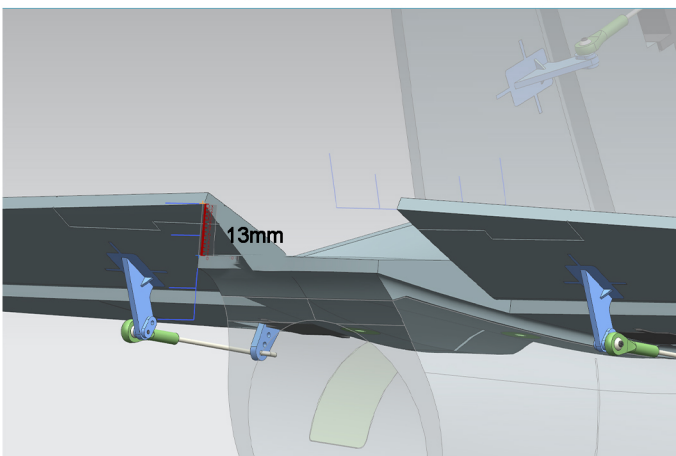

Elevator large control surface (80-90%)

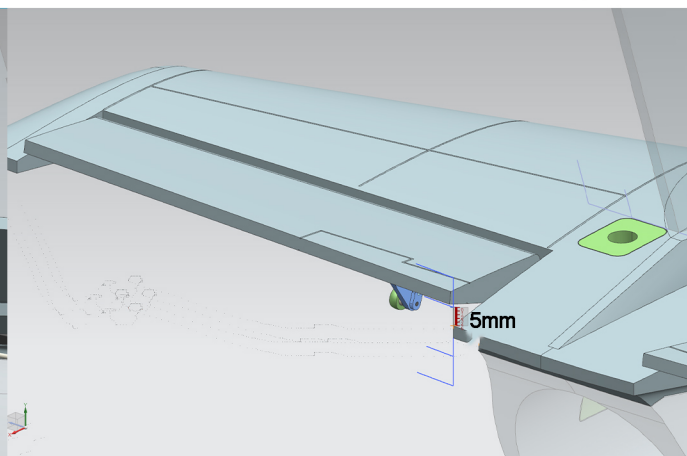

Elevator small control surface (35-45%)

Flight Tuning Precautions

- This aircraft generates significant overall lift and boasts excellent low-speed performance. Please pay attention to the battery placement, ensuring that the nose is slightly heavier but avoiding a light nose.
- The 6S version of the battery can be used with batteries ranging from 2000mAh to 3300mAh.
- When the flaps are deployed, the aircraft may experience a slight nose-up tendency, and the deceleration effect will be noticeable. Pay attention to maintaining speed during landing.
- During landing, you can fully close the throttle. After the speed and altitude have decreased, apply a slight throttle input to avoid stalling.
- The aileron control is highly effective; refrain from using excessive control deflection during normal flight

Trouble shooting

Problems	Probable Causes	Solutions
Aircraft will not respond to the throttle but responds to other controls.	<ul style="list-style-type: none"> • ESC is not armed. • Throttle channel is reversed. 	<ul style="list-style-type: none"> • Lower throttle stick and throttle trim to lowest settings. • Reverse throttle channel on transmitter.
EDF noisy or vibrating excessively.	<ul style="list-style-type: none"> • Damage or malfunction of spinner, blades, motor, etc. • Loose motor mount or EDF installation. 	<ul style="list-style-type: none"> • EDF has high-speed rotating components. Damage or malfunction can cause imbalance. It is not recommended for users to repair themselves; Factory repair is recommended. • Tighten screws and secure motor mount and EDFs.
Reduced Flight time or aircraft underpowered.	<ul style="list-style-type: none"> • Battery not fully charged • Low discharge rate • Battery malfunction 	<ul style="list-style-type: none"> • Completely recharge battery. • Replace with high discharge battery. • Replace battery.
Control surface does not move, or is slow to respond to control inputs.	<ul style="list-style-type: none"> • Control surface, control horn, linkage or servo damage. • Wire damaged or connections loose. 	<ul style="list-style-type: none"> • Replace or repair damaged parts and adjust controls. • Do a check of connections for loose wiring.
Controls reversed.	<ul style="list-style-type: none"> • Channels are reversed in the transmitter. 	<ul style="list-style-type: none"> • Do the control direction test and adjust controls for aircraft and transmitter.
Sudden power reduction during Flight	<ul style="list-style-type: none"> • ESC enters low-voltage protection mode. • Motor or battery malfunction. • ESC enters overheat protection mode. 	<ul style="list-style-type: none"> • Immediately land and check battery voltage. • Check components such as battery, transmitter, receiver, ESC, motor for faults • If the ESC temperature is too high due to high environment temperature or prolonged continuous Flight, allow it to cool down.
Receiver LED blinking slowly	<ul style="list-style-type: none"> • Power loss to receiver. 	<ul style="list-style-type: none"> • Check connection from ESC to receiver. • Check servos for damage. • Check linkages for binding.